

# Extending the KVM Video Range to 1.5k Ft

The present KVM extension solution, Intersil's 'Hermes' board, support RGB video transmission down Cat 5 cable to about 1,000ft. Yet, you can extend this solution to 1,500ft by simply adding a pre-compensation network cable driver. This pre-comp driver is inserted between the EL4543 line driver RJ45 output plug and the Cat 5 cable to extend the range by 500ft (refer to Figure 3). We will also offer an option which you can connect directly to the computer's VGA video output plug to extend the range of the PC's RGB output on Cat 5 cable.

## Problem

Cat 5 is not an ideal transmission medium for video yet, is very economical vs using RG-59 Coax. The present KVM solution used the EL4543 which embeds the  $H_{SYNC}$  and  $V_{SYNC}$  as a difference common mode signal onto the RGB line pairs. The embedding of the sync's reduces the cable requirement to just three twisted wire pairs in a Cat 5 cable bundle of four wire pairs. The present KVM solution is good to about 1,000ft and uses the EL9111 or three EL9110s to receive and extract the  $H_{SYNC}$  and  $V_{SYNC}$  from the RGB. Yet, the longer the Cat 5 cable, the more the signal losses of the higher frequencies. For a flat frequency response needed for video, the cable will need compensation. Cat 5 cable losses are about 3dB per decade so simple RC passive circuits to boost the HF components will not compensate for such losses. How then is the range extended by 500ft?

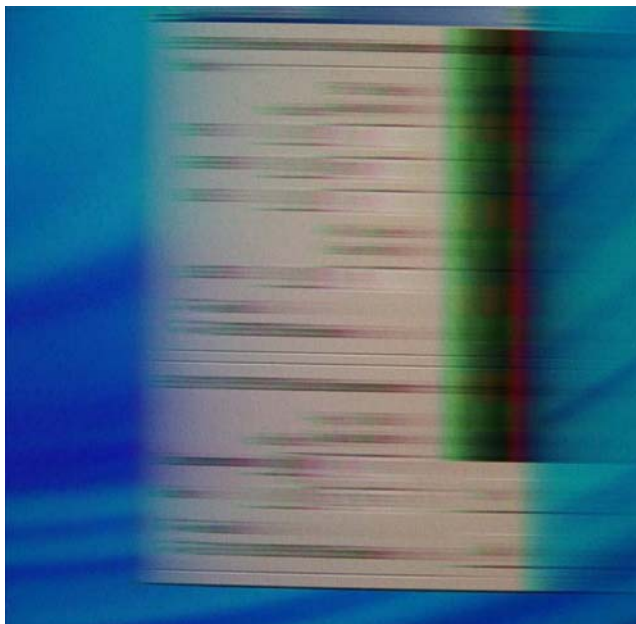

**FIGURE 1. RGB DOWN 1,500ft CAT 5 NO COMPENSATION**

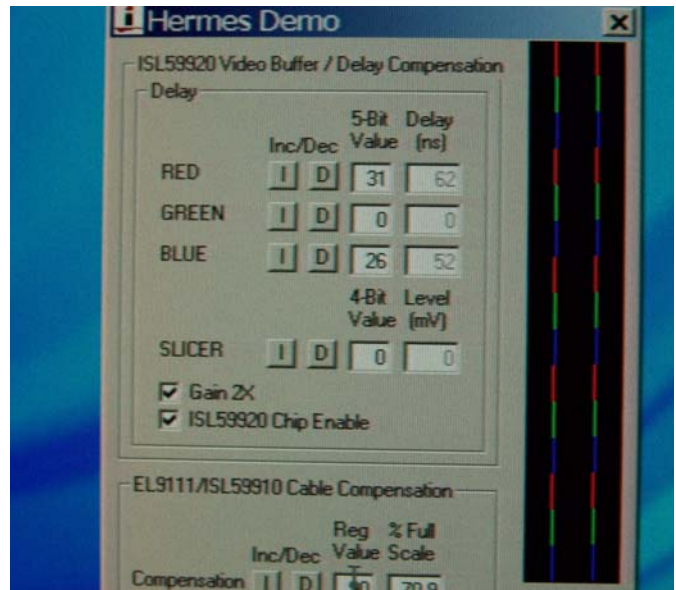

**FIGURE 2. HERMES' BOARD COMPENSATION WITH THE 5009' DRIVER EXTENTION**

## Solution

This application note will address using active peaking circuitry at the driving end of the Cat 5 cable to extend the usable range an additional 500ft. The same peaking circuit can be used to extend standard RGB output from a PC up to 500ft as well. Key is insuring the high frequency elements, such as the  $H_{SYNC}$ ,  $V_{SYNC}$  and color information are peaked in such a manner to overcome Cat 5 cable losses. This design is done in the analog domain to maximize the overall performance at the lowest cost.

We will discuss one channel, the other 2 channels will need to be replicated for a complete RGB system.

## The Amplifier

The amplifier peaks the incoming RGBHV of the EL4543 and drives the long distance Cat 5 cable (See Figure 4). To accomplish this, we will need to complete the following steps:

1. Impedance match the incoming Cat 5 to the peaking network.
2. Adjust the sync CMV level to within the input range of the Amp to optimize its operation.
3. Add peaking circuitry to correct sync offset rising and falling edges due to the CMV offset circuit.
4. Peak the three critical portions of the signal, which are the Flatness, High Frequency components and the DC Gain level

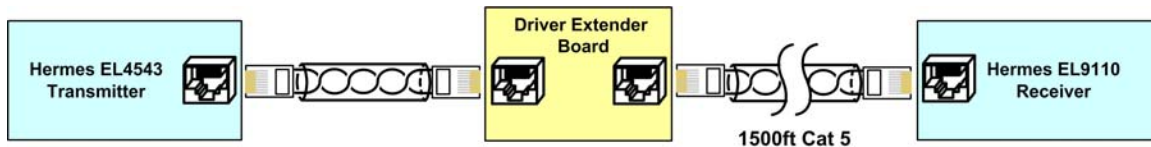

FIGURE 3. PLACEMENT OF THE DRIVER EXTENDER BOARD

## Basic Overall Circuit Description

The compensation circuitry needs a very high BW to provide the gain for the high frequency elements of the incoming video signal. We selected the EL5378 Triple 700MHz Differential Twisted-Pair Driver as the basis for the incoming amplifier and peaking network. Key for its selection is the wide bandwidth and unique differential input structure and its external reference input. This unique input structure isolates the input from the feedback network, greatly reducing design problems. We can set the Gain and Offset without being concerned about how they would negatively impact the input video signal.

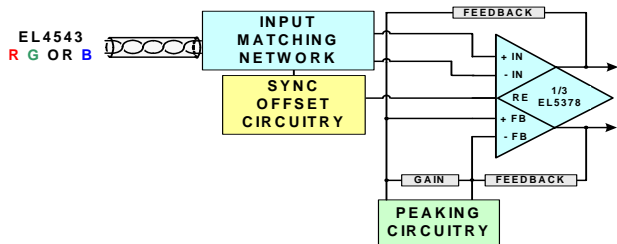

FIGURE 4. BASIC BLOCK DIAGRAM OF THE CIRCUIT

### EL4543 RGB with Differential CMV Sync Encoded

The EL4543 is normally used as a 0V to 5V video amplifier with the output offset to half the supply voltage of 2.5V. The EL5378 must be used at  $\pm 5V$  to allow for the frequency peaking voltage output range. Thus, the output of the EL4543 must be offset to match the 0V input need for the EL5378. If the EL4543 is used at  $\pm 5V$ , then the output has no offset and the offset circuit can be set for 0V offset with a switch.

#### INPUT MATCHING NETWORK

(Refer to Figure 6) The incoming R, G or B video is a differential signal. Once the differential signal is properly matched and adjusted to the input of the EL5378 (Input Matching Network), the signal will require a 2x gain to compensate for the output cable termination loss of the EL5378. The EL5378 is a differential amplifier and to set the gain will require the classic two feedback resistors from the outputs to the feedback pins and a gain resistor between the feedback pins.

#### SYNC OFFSET CIRCUITRY

The peaking circuitry needs to be applied to the R, G or B incoming signals separately. The  $H_{SYNC}$  and  $V_{SYNC}$  are encoded on the R, G and B differential signal lines by the EL4543. The encoded  $H_{SYNC}$  and  $V_{SYNC}$  will need to be

recovered and repled as a common mode voltage (CMV) to the amplifier insuring the CMV range of the amplifier is optimized.

The Sync Offset circuit will also reduce the sync amplitude by 1/3 due to the series 1k and 2k resistors, thus requiring modification of the gain in order to peak the syncs leading and trailing edge and recover the sync amp.

#### Peaking Circuit

The Cat 5 cable signal losses are at a higher frequency. For a flat frequency response needed for video, the cable will need compensation. Cat 5 cable losses are about 3dB per decade. Thus, simple RC passive circuits will not work.

Even though the video signal has gained up to recover the termination loss, there is a need to selectively peak the gain for certain bandwidths as the Cat 5 cable effects different frequency bands differently. Thus, developing a peaking/frequency boost network to compensate for this effect. The peaking network is connected across the gain resistor to adjust the gains at different frequencies.

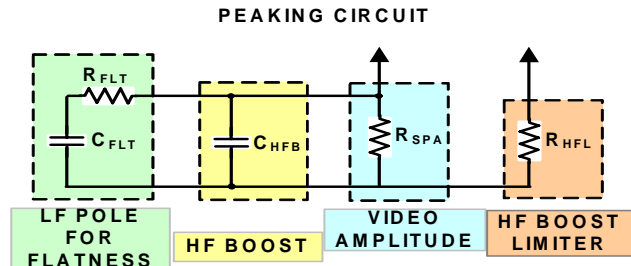

FIGURE 5. PEAKING CIRCUITRY

The peaking network selected, is a classic configuration with separate R, C and RC elements to modify the gain for Flatness, HF Boost and Video Amplitude. The single capacitor,  $C_{HFB}$  will peak the highest frequencies and the network gain resistor controls the peak gain/sharpness. The additional series RC network,  $R_{FLT}$  and  $C_{FLT}$  form the low frequency pole to determine the flatness of Back Porch. The last resistor to ground,  $R_{SPA}$ , determines the height of the low frequency video. We added  $R_{HFL}$  to gain limit the HF Boost for stability and reduce HF noise.

The Peaking circuit is parallel to the DC gain resistor which modifies the overall gain of the amplifier to generate a flat frequency response needed for video. You can break down the video requirements into four different parts (refer to Figure 5):

1. **SYNC Flatness** – The Back Porch flatness sets the overall luminance reference for the horizontal scan.

Using a simple low frequency pole to peak the gain at low frequencies ensures the received back porch at the other end of the cable will be reasonably flat. A simple series RC forms the low frequency pole.

2. **HF Boost** – Since the Cat 5 cable has greater losses at higher frequencies, we use a capacitor to peak the gain at high frequencies.
3. **Video Amplitude** – A simple resistor can insure we have correct gain. Why not just use one resistor to set the DC gain? We will explain our reasoning in the following sections.
4. **Limit HF Boost** – We use a small value resistor to reduce the effect of the peaking circuit on the summing node of the EL5378. This resistor will limit the HF Boost, prevent the circuit from going into oscillations, and help reduce the HF noise from being amplified. A small series resistor is used to reduce the effects of any capacitance you may have on the summing node and their effects. More on this topic is discussed later in this application note.

## Detail Circuit Description

### Input Matching Network (Figure 6)

The input network is set up to terminate the Cat 5 cable impedance with two 51Ω resistors in series across the cable for a 100Ω load match. We use two series resistor to establish a mid point for Sync Extraction.

### SYNC Extraction w/Offset Adjust

We can use the midpoint of the two resistor termination and extract the common mode Syncs. We can also use the same node to apply the required CMV adjustment.

The encoded  $H_{SYNC}$  and  $V_{SYNC}$  are recovered by the 1k resistor parallel with the 0.1μF capacitor to the 51Ω mid point. If the EL4543 is operating in single supply mode, +5VDC, the CMV point will be at 2.5VDC. In turn, the EL5378 operates with a dual supply of ±5V and its common mode zero point is at 0VDC. Thus, we must have the REF input and the DIFF output at 0V average. To accomplish this, we need to offset the incoming Sync by -2.5VDC to force Syncs CMV to match the EL5378s CMV. We can connect a 1k resistor from the termination

mid point in series with a 2k resistor terminated at -5V, to offset the Sync by -2.5VDC. If the source (EL4543) is operated at ± 5V, then the offset is not needed and the 2k resistors should be connected to ground. A universal option is given by using switch S1, see Figure 1, to connect the 2k resistors to ground or -5V. The 1k and 2k induce a 1/3 loss of the sync signal amplitude but the 0.1μF capacitor will give the edges a full level signal so that no useful sync signal is lost.

### Peaking Circuit

Even though the video signal has been gained up, certain bandwidths need to be selectively peaked as the Cat 5 cable effects different bands differently. It is then necessary to develop a peaking/frequency boost network to compensate for the cable effect. The discussion on how to design this circuit will not be discussed, however, we will mention how it works. The key point to remember is that each of the peaking networks is additive.

### LIMITING THE HF BOOST

The EL5378 is not truly a 2x gain amp due to stray PCB capacitance impacting the HF frequency gain. This small stray capacitance will peak the gain at other higher frequencies. It is near impossible to remove all the stray capacitances but it is possible to reduce the stray capacitance. However, this stray capacitance will cause the gain to be peaked at other than the desired frequencies. By placing a small resistor after the selection switch (see Figure 6) close to the summing node, will act as an isolation resistor to the stray capacitance by reducing the overall Q of the parasitic capacitors. The reasoning for being concerned about stray capacitance is the more capacitance you have on the summing node the more unstable the wide band amplifier becomes. Make sure to place these resistors very close to the summing node, to further reduce the stray capacitance of the PCB trace between the resistor and the node. Also, for the components that form the summing node, keep the physical distance to a minimum. As for the basic layout guidelines, use a good ground plane and a ground plane moat under the summing node and the network RCs to help reduce noise and stray PCB capacitances.

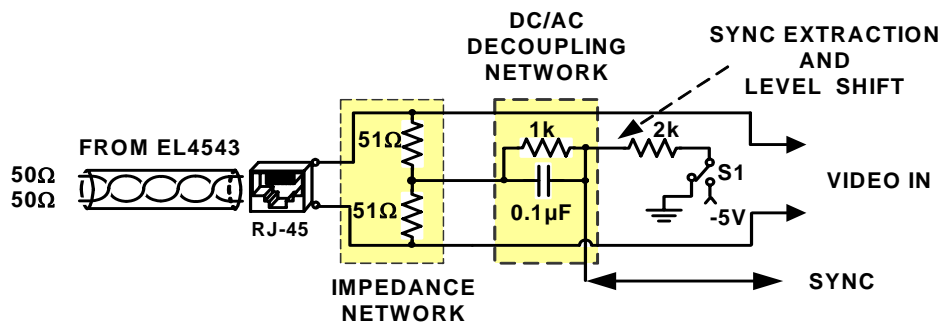

FIGURE 6. INPUT IMPEDANCE MATCHING NETWORK

## Improved Design Using Selectable Range 150ft, 300ft and 450ft (150ft + 300ft)

This design covers from 1,000ft to 1,500ft. Yet, it does require trade-offs if implemented in a single peaking circuit. The high frequency losses of the Cat 5 cable changes dramatically as the cable length increases. Yet, if the peaking circuits are optimized for a given increment of Cat 5 cable length, the networks are able to be connected in parallel, compensating the driver for different cable runs as needed. By dividing the additional 500ft into two, 1/3 and 2/3's, we can optimize the peaking for each length, improving the overall performance. Now, using superposition, the two different peaking circuits are able to be added, achieving an overall length of 450ft.

Range selection can be done by using a simple low capacitance mechanical SPST switch. A simple selector switch will give us the flexibility to use this circuit in many applications for cable lengths from 1,000ft to 1,150ft to 1,300ft to finally 1,450ft with minimal degradation in the video signal.

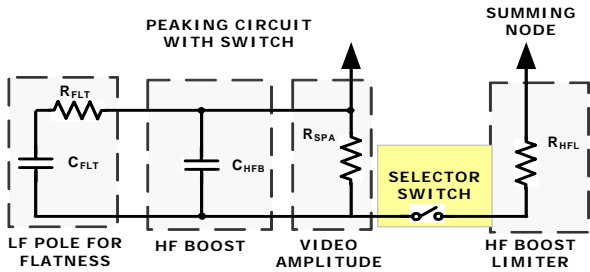

FIGURE 7. SELECTOR SWITCH PLACEMENT

At this point, we have gone through the quantitative experimentation and have come up with our recommended values for the peaking circuit components. To help isolate these stray capacitances, the switches should be connected upstream of the peaking network, before the HF Boost Limiter resistor and closest to the In-Amp's summing node right at the gain resistor.

The peaking circuit is designed to peak the desirable HF elements by using an edge enhancement HF Boost RC network, a parallel H<sub>SYNC</sub> pulse flatness RC network, a parallel DC video amplitude network and a switch to add peaking as function of the cable length. The peaking circuit is designed to peak the desirable HF elements by using an edge enhancement HF Boost RC network, a parallel H<sub>SYNC</sub> pulse flatness RC network, a parallel DC video amplitude network and a switch to add peaking as function of the cable length (see Table 1).

TABLE 1. TYPICAL PEAKING NETWORK VALUES BY CAT 5 CABLE LENGTH

CAT 5e	FLATNESS		HF BOOST	SYNC TIP	HF BOOST LIMITER
LENGTH (ft)	R <sub>FLT</sub> (kΩ)	C <sub>FLT</sub> (pF)	C <sub>HGB</sub> (pF)	R <sub>SPA</sub> (kΩ)	R <sub>HFL</sub> (Ω)
150	5	75	20	34	510
300	2	130	47	16	255
500	1.43	200	68	11	170

## Test Results

There is the same image at 1500ft with the hermes board and the extender circuit. Using the Herme's design and extended board full range compensation, you can see in Figure 8, the images are very useful.

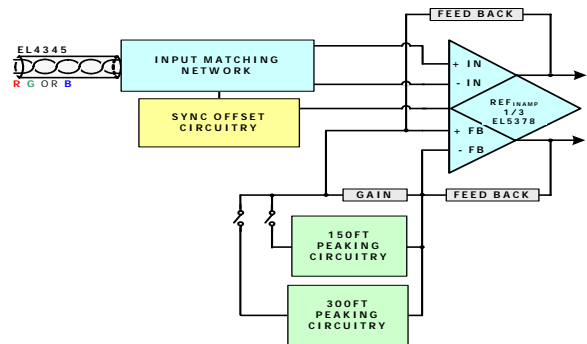

FIGURE 8. COMPLETE BLOCK DIAGRAM

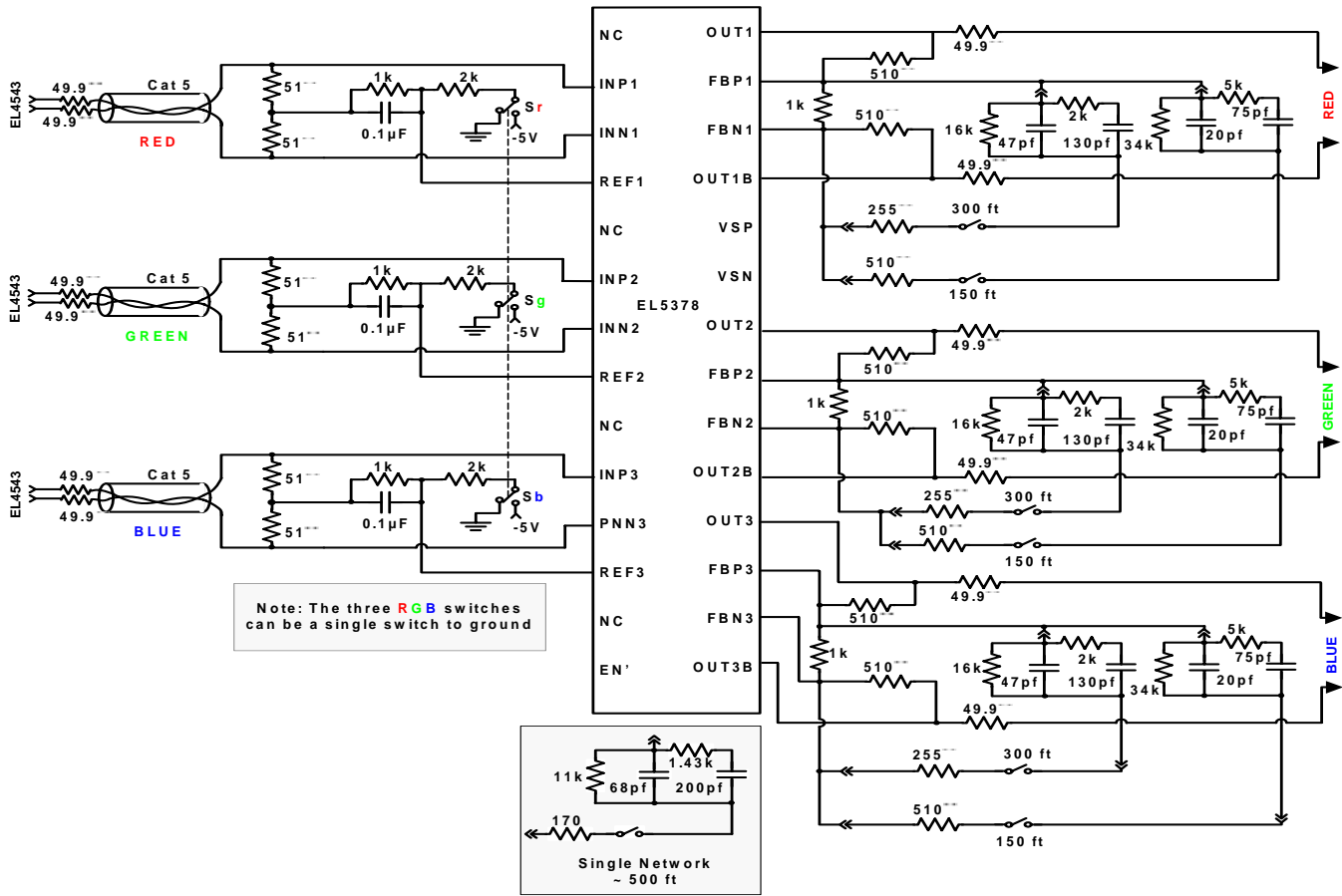

FIGURE 9. COMPLETE RGB EXTENDER CIRCUITRY

## Extending the RGB+HVsync Output from Your PC

We can use the same peaking network to also extend the RGBHV from your PC by simply encoding the H<sub>SYNC</sub> and V<sub>SYNC</sub> as is done in the EL4543 but do it descreatly using simple digital NAND gates (74HC00). We will also need to encode, then offset and scale these signals so they can be added on the R, G and B as we did in the previous circuit (Refer to Figure 10).

### STD LEVEL BUFFER AND ENCODER

The buffer will shift the input levels to a simple logic level for the logic encoding. We can use a simple HCMOS logic device to perform both the Level Buffer and the Encoding.

### OFFSET ADJUST AND SCALER

We need to offset this ground reference logic level Syncs to a common mode voltage average of 0V. Thus, as with the previous circuit, we will need to offset the Syncs negatively to remove the DC offset from the logic device output.

## Extending the RGB + HV<sub>SYNC</sub>

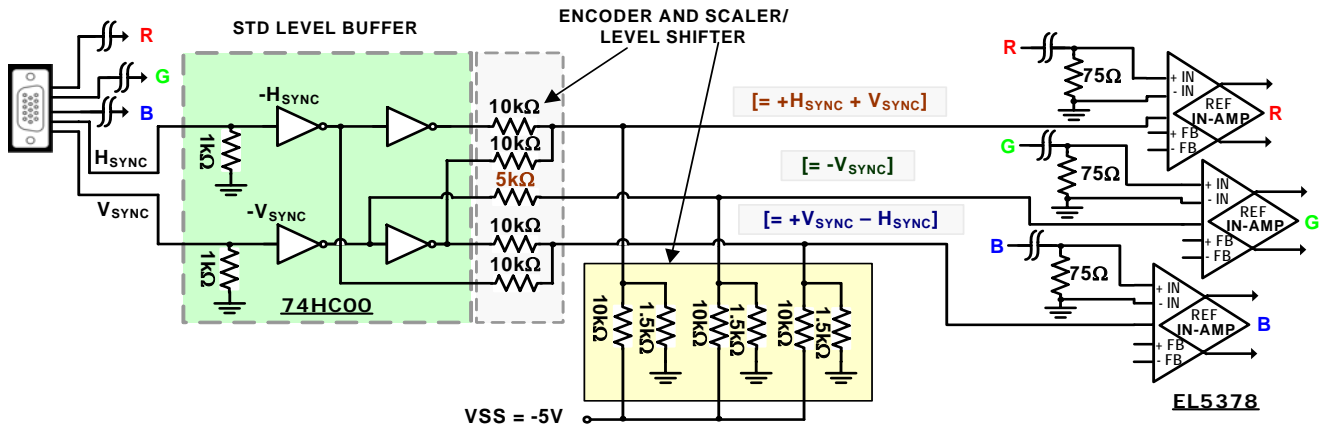

FIGURE 10. DETAILED PC RGB EXTENDER

### Circuit Details

#### STD Level Buffer (Figure 10)

The H<sub>SYNC</sub> and V<sub>SYNC</sub> coming from the PC are referenced to ground using a 1kΩ resistor as a standard load. We use a very low cost logic gate, such as the HC00 on the H<sub>SYNC</sub> and V<sub>SYNC</sub> inputs, setting to known levels as source to the encoding. The outputs are H<sub>SYNC</sub> and V<sub>SYNC</sub> both inverted and non-inverted.

#### Encode

We need to buffer the input to the Ref of the EL5378. We use 10kΩ series resistors at the output of the buffers to prevent these outputs from loading each other and at the same time properly encode the H<sub>SYNC</sub> and V<sub>SYNC</sub>. The output of each is 5k in order to simplify the configuration. Now we have encoded the output of the buffers to the Sync sum/differences as generated internally by the EL4543.

#### Offset and Scale

Scaling and level shifting of the Syncs is done in one simple resistor divider. Using a simple resistor divider network tied to -5VDC, we can offset each Sync combinations as needed before applying them to the EL5378 Reference inputs. Reference Inputs are as follows:

RED [+ H<sub>SYNC</sub> + V<sub>SYNC</sub>]

GREEN [- V<sub>SYNC</sub>]

BLUE [+ V<sub>SYNC</sub> - H<sub>SYNC</sub>]

Figure 10 shows that, all the buffer outputs resistor networks have the same 5k output impedance and the 10k to -5V. This gives us a 0V output with ±1.66V sync levels at 3.33k source and with 1.5k to ground giving ±0.5V sync output levels to the Ref.

The H<sub>SYNC</sub> and V<sub>SYNC</sub> are now properly encoded matching the encoding scheme of the EL4543. The encoded Syncs are applied to the V<sub>Ref</sub> of the EL5378. Thus, the PC RGB signals are single ended outputs. The VGA cable RGB lines are connected to a 75Ω termination resistor and the INP inputs of the EL5378 and the INN inputs to ground. This configuration with the 75Ω termination resistor will properly terminate the video signal. We still need to keep the 2x gain to overcome the termination loss.

RGB pairs have no standard cable pin out so be sure you use the same cable pin out as your receiver.

Cable pinout for cat 5 RJ45 input board design should be correct to insure the sync is on the correct color line so the sync decode will work.

The cable pin out used is the same as used on the Intersil EL4543 'HERMES-DEMO-BOARDZ'.

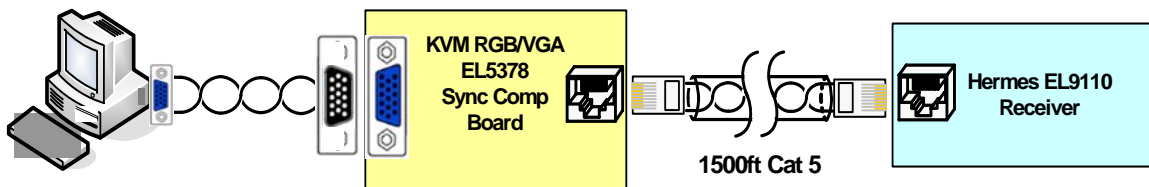

FIGURE 11. PLACEMENT OF THE RGB/VGA SYNC COMPENSATION BOARD

# Application Note 1484

## Notes to Consider

1. RGB pairs have no standard cable3 pinout. So be sure you use the same cable pinout as your receiver.
2. Cable pinout for Cat 5 RJ45 input board design should be correct to insure the Sync is on the correct color line. Otherwise, the sync decode will not work.
3. The cable pinout used is the same as used on the Intersil EL4543 HERMES-DEMO-BOARDZ, see Figure 12.

## Test Results

1. Results for experimentation and testing: The video band width is about:
  - 160MHz at the 150ft range
  - 110MHz at the 300ft range
  - 85MHz at the 450ft range

These test results are similar to the EL9111 at max range of 1000ft.

2. Cat 5E cable skew starts to show up at about 300ft. We recommend the use of a deskew IC like the EL9115 or ISL5920 for Cat 5E cables greater than 300ft.

## Complete Schematic and PCB Layout

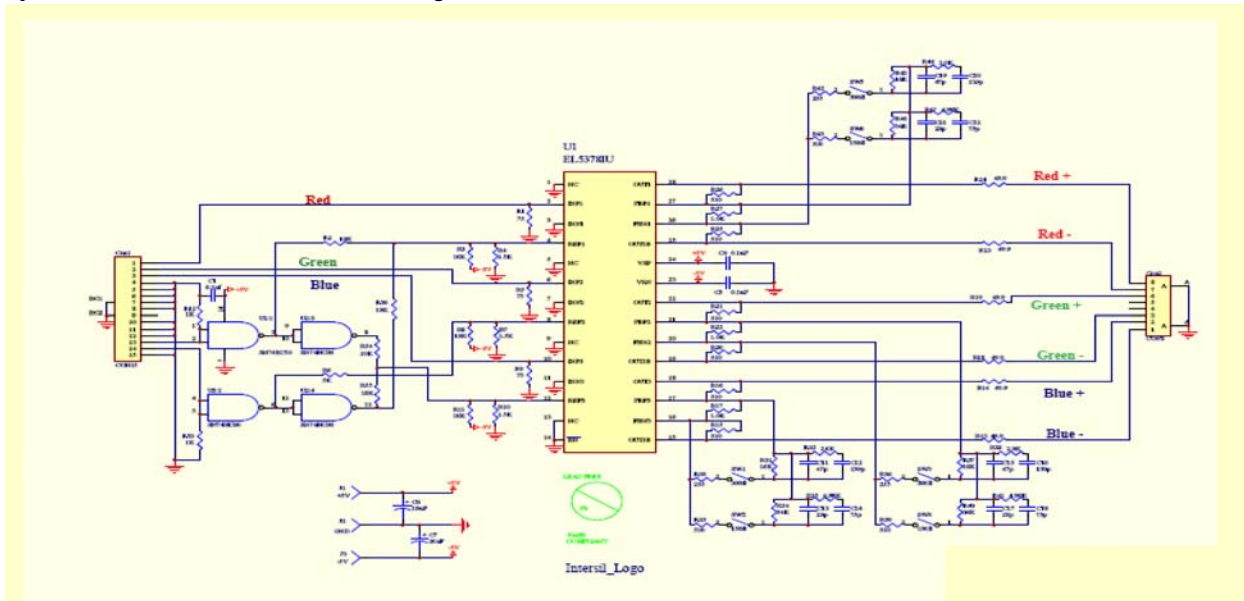

FIGURE 12. KVM RGB w/CMV SYNC-CABLE COMPENSATION SCHEMATIC

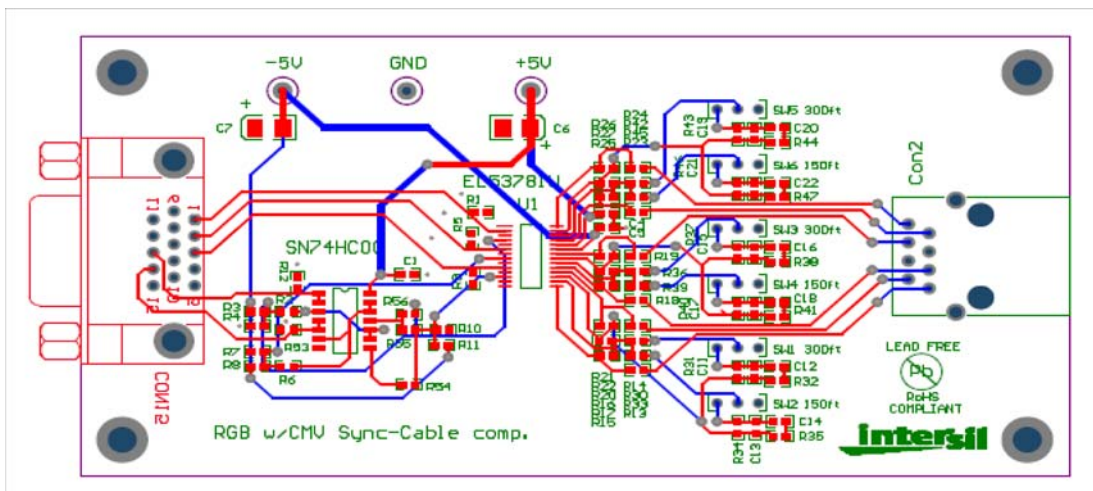

FIGURE 13. KVM RGB w/CMV SYNC-CABLE COMPENSATION PCB LAYOUT

## Appendix

Cat 5 cable pair Video color selection Problems and Solutions:

**Problem** - The cat 5 cable pairs have different twist rates to reduce the crosstalk. However, the different twist rates causes the prop delay to be different for each pair. Using the pairs for good color video reproduction requires the colors arrive at the same time so they will align with each other. The different twist rates causes the colors to arrive at the monitor at different times. The result is having three different color images next to each other.

**Solution for Deskew ICs** - To optimize the performance of the deskew IC, select the wire pairs to minimize the RGB skew caused by the cable's different twist rates. Our testing has shown that the skew is about 24ns to 32ns for nearest skew pairs. Three twisted wire pairs have been tested at the standard Cat 5 RJ45 pins. The wire pairs associated with pin pair 1–2 is the shortest pin pair 3–6 is the middle and pin pair 7-8 is the longest.

### Recommendations

For optimum performance, we recommend the shortest pair (pins 1–2) to be the Blue signal, which will require the longest delay. The Green (pins 7-8) should be the longest pair and be the reference or zero delay, thus, needing no correction. Then, the middle, Red (pins 3–6). The selection for the RED and Green pairs is not very critical when using a deskew IC but the Blue wire pair should have the longest delay.

### DeSkew Solution

There are a number of applications where added deskew is needed. Such as, when a Hermes type KVM receiver cable comp board is used and a cable longer than 1000ft is needed, then a pre comp cable driver can be used but more deskew will be needed. By designing an IC deskew board unit with computer (VGA cable plugs on the input and output and a USB plug) then it can be added to the output of an existing cable receiver to get the needed deskew added. The deskew unit can be connected to the input of the pre comp cable driver. This will allow an extra long cable to be added to a working system. For new systems the extra IC de skew chip can be designed in as needed.

Another application for a deskew unit is for shorter up to 500ft cable using the EL4543 as a cable driver and the application note in the data sheet using the EL5375 used as the cable comp receiver.

### Add Deskew to New Receiver Design

The extra skew from the added 500ft of cable should be corrected at the cable receiver if possible. It will be easier to implement at the receiver.

The deskew IC is best placed just before the receiver VGA plug at the output to the monitor. The RGB lines are separated from the embedded H<sub>SYNC</sub> and V<sub>SYNC</sub> so just the RGB is available at the VGA plug.

### Adding 500' Cat 5 Skew Problem - A Low Cost Work Around

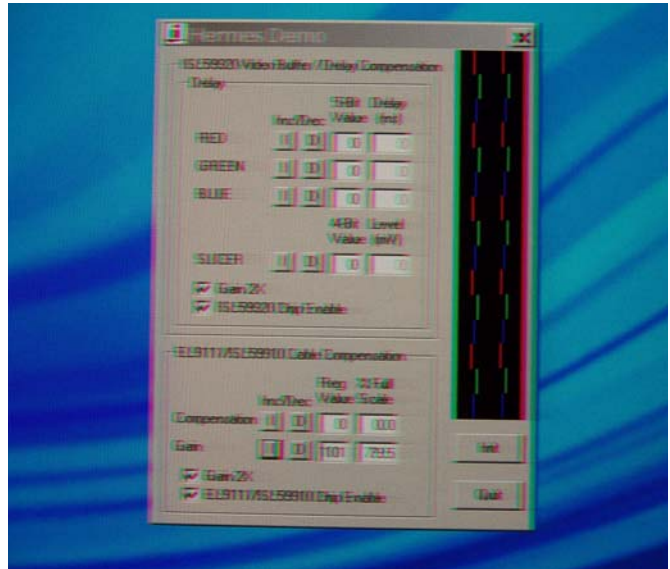

FIGURE 14. SKEW AT 500' NO COMPENSATION

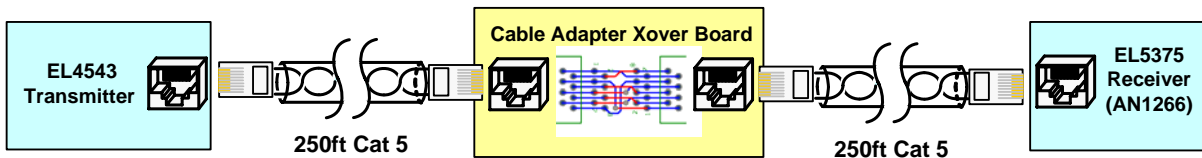

FIGURE 15. PLACEMENT OF THE CABLE CROSSOVER BOARD



## Notes:

1. Most of the skew may be canceled by using two 250ft alike Cat 5 cables in series to make 500ft cable. At the middle of the 500ft cable, you swap the longest and shortest video lines and at the receiver swap them back.
2. When a deskew IC is used in the system with over 1k feet then the two cables can be of different length, as long as the deskew IC can correct the difference in the two cable lengths. A 1k feet cable with 500ft cable with longest and shortest video pairs reversed at both ends of one cable, will have only 500ft of skew remaining that the deskew IC can correct.
3. Cable adapter boards, see Figures 16 and 17, may be used to rearrange the color pairs with existing systems to get better color performance with the KVM extender at 1500ft to optimum color pair assignments. When an added deskew IC is not used then there will be blue color error but generally will be small. This will give a low cost solution with good performance to about 1300ft and reduced performance at 1500ft on Cat 6 cable.

The cable adapter cable wiring crossover will need to be designed as needed for the application. The adapter crossover shown is for Hermes improved pair selection.

The cable adapter board may be configured for color pair long to short pair reversal. The same adapter is used in the middle and one end of the cable and just reversed in direction. The "Cable" labels should go to the same cable.

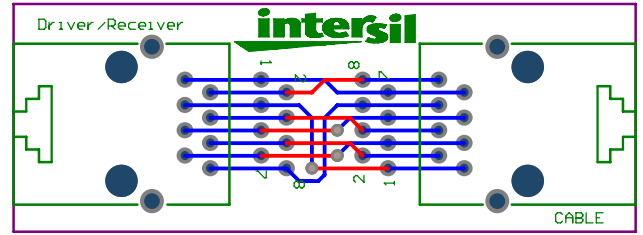

FIGURE 17. CABLE ADAPTER BOARD

## Dielectric Cable Smear (Dielectric Storage Effect)

If you look close at Figure 18, you will see a smearing to the right of any Dark to Light or Light to Dark color transition. This is referred as a cable smear, the result of the twisted wire insulation dielectric absorption.

The rise time of the cable causes short time constant smear that is corrected with cable compensation. However, the dielectric insulation in the cable has dielectric absorption that causes electrons to be stored in the dielectric. When there is a voltage across the dielectric, the electrons are not just on the surface but go into the dielectric and are stored there. Therefore, when the voltage is removed, the electrons are slowly released. In a long cable that is at one voltage for a number of micro seconds followed by a larger voltage change, there is a charge or discharge of the electrons that changes the voltage on the cable that shows up as a long time constant of a number of micro seconds of smear. This can only be fixed by a low dielectric absorption cable.

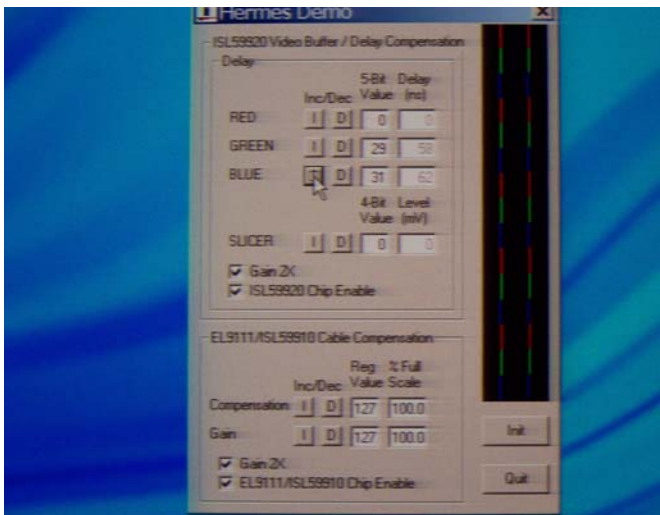

FIGURE 16. 500' WITH THE ADAPTER BOARD

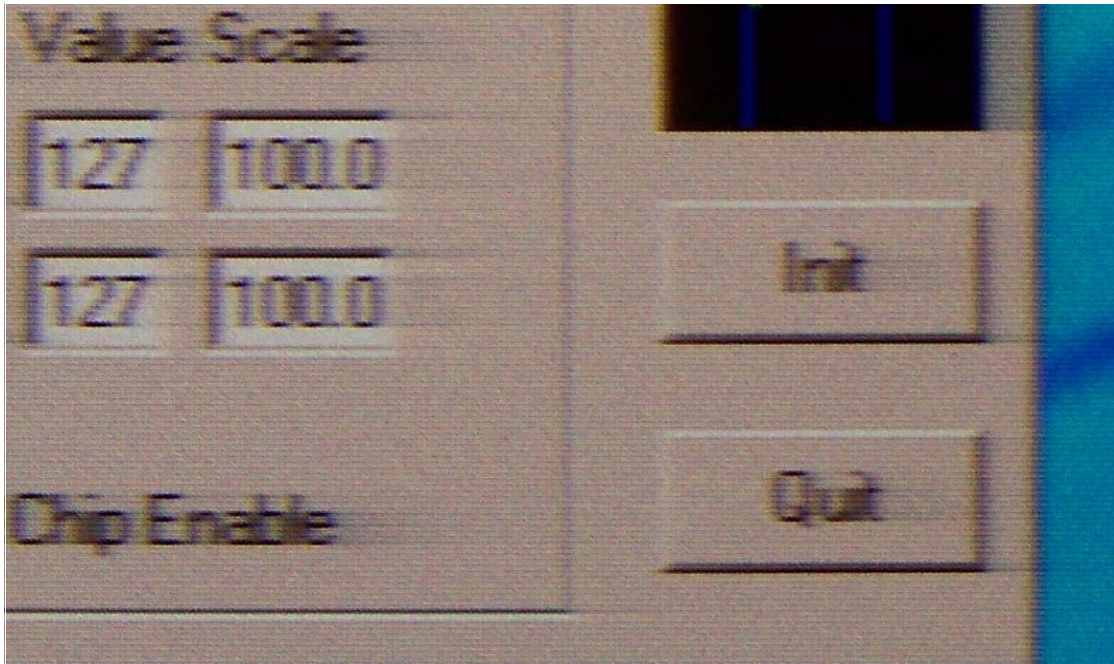

FIGURE 18. EXAMPLE OF CABLE SMEAR

### ESD Protection

Figure 19 does not have ESD protection shown. ESD protection should be added as needed with a Schottky diode, we recommend the BAT54S dual diode be connected from the plus and minus supplies to the output and input cables. Transit Voltage Suppressors should be added if the cables are exposed outdoors. The placement should be close to the first IC encountered from the input of the receiver. For short runs this would be the input to the EL537x and for long runs requiring deskew, this would be the input to either the EL9115 or ISL5992x.

# Application Note 1484

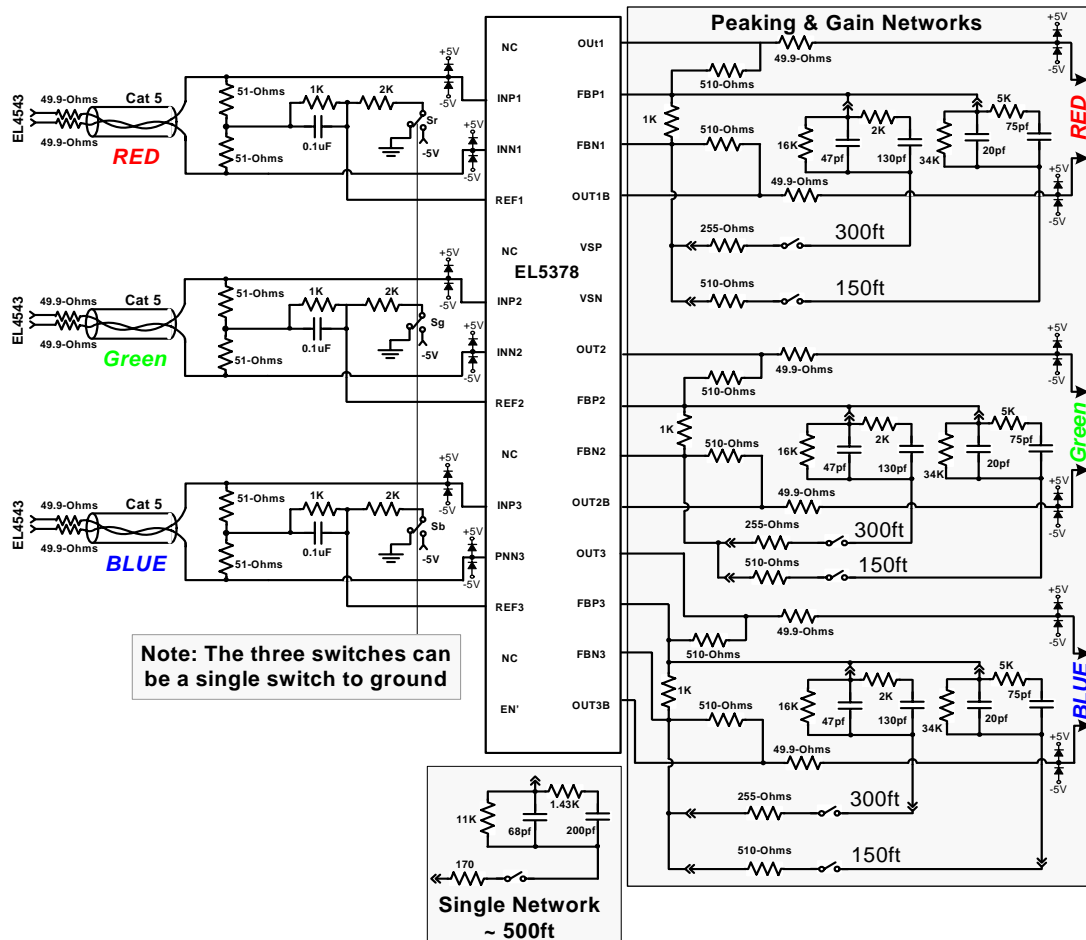

FIGURE 19. COMPLETE COMP CIRCUITRY WITH ESD PROTECTION

## Add De-Skew to New Pre Comp Driver

When the cable receiver does not have the range to correct the added skew, and the added deskew cannot be added at the receiver, then the additional correction can be added at the cable driver end. The Cat 5 cable has a fourth digital control wire pair which can control the logic from a USB port, for a remote deskew IC at the cable driver. You can now control the deskew from the remote KVM station using the fourth cable pair for the deskew logic control.

The deskew IC is then connected from the of the VGA board input to the RGB input of the EL5378. The 75Ω termination resistor stays with the cable. The USB interface to the deskew IC and the software is needed to support the remote deskew control. The interface for the deskew IC is in its data sheet and in the HERMES-DEMO-BOARDZ' documentation.

Intersil Corporation reserves the right to make changes in circuit design, software and/or specifications at any time without notice. Accordingly, the reader is cautioned to verify that the Application Note or Technical Brief is current before proceeding.

For information regarding Intersil Corporation and its products, see [www.intersil.com](http://www.intersil.com)